

## Rapid Bacterial Swimming Measured in Swarming Cells of *Thiovulum majus*

FERRAN GARCIA-PICHEL

Department of Biology, University of Oregon, Eugene, Oregon 97403

Received 14 November 1988/Accepted 13 March 1989

**Swarming cells of the sulfide-oxidizing bacterium *Thiovulum majus* form bands and show bioconvective patterns of swimming when placed in vessels containing H<sub>2</sub>S/O<sub>2</sub> interfaces. Measurements of swimming velocities with video microscopic recordings under such conditions showed mean cell speeds as high as 615 μm s<sup>-1</sup>, unprecedented in bacteria.**

*Thiovulum majus* is a sulfide-oxidizing eubacterium that thrives at the interfaces of hydrogen sulfide and oxygen in nature (4, 12), where it forms conspicuous slime veils. Although it has long been known to microbiologists (3), no permanent pure cultures have as yet been established. When conditions are such that the veil cannot keep the interface within its boundaries, *T. majus* cells swarm off the veil en masse. These events can also be followed in enrichment cultures, in which bands of cells and bioconvective patterns appear (Fig. 1), similar to those described for purple sulfur bacteria (7) or phytoflagellates (6). Free-swimming cells display strong, finely tuned chemotaxis to trace amounts of oxygen and fast swimming. These characteristics have been noticed in the past and have been used to achieve purified cell suspensions (5, 12).

The bioconvective patterns were recreated in 3-ml glass vials and cuvettes, and time-related characteristics suggested a very high swimming velocity, closer to that of unicellular eucaryotes.

Two enrichment procedures were used. In the first procedure, a 2-dm<sup>2</sup> piece of microbial mat from the Great Sippewissett salt marsh (Woods Hole, Mass.) was placed at the bottom of a cylindrical glass container and filled with seawater, with a slow flow of oxygenated seawater moving through the top. After remaining in the dark for 1 day, sulfide production in the mat and fresh seawater flow created an oxygen/hydrogen sulfide interface. This was optimal for the development of a veil of *T. majus* that persisted for many days. This enrichment procedure was unsuccessful with coastal mats from Coos Bay, Oregon. A mixture of decaying macrophytic algae was then used as an alternative source of sulfide: enrichment for *T. majus* became evident after several weeks. Samples from the raw enrichments were pipetted and placed in filter-sterilized seawater, where swarms of cells swam from the pieces of veil and congregated in certain areas. There, they were repipetted and transferred to the experimental vessels. Glass vials (3-ml capacity) or spectrophotometric cuvettes (with sulfide-agar plugs, when gradients were to be created) were used to reproduce and study bioconvective patterns. Microscopic chambers, as depicted in Fig. 2, were constructed for video microscopy of the cells and patterns. The chamber was filled with seawater, and a bubble of H<sub>2</sub>S gas was created at the bottom by carefully injecting the gas through the pipette with a syringe. After inoculation and monitoring of cell behavior, movement of the cells could be microscopically recorded. Cell velocities

were calculated in recordings of preparations not undergoing bioconvection by tracing trajectories of single cells on the television screen, monitoring them frame by frame. The absence of bulk flow was further tested by monitoring inert particles in the recordings. By applying the proper frame per second and magnification conversions, real speeds were easily determined.

Formation of steady bands of cells in microchambers was achieved with different amounts of inoculum, depending on the kind of medium (homogeneous or gradient) used. Congregation of the cells into bands usually became visible shortly after inoculation (30 s to 1 to 2 min). For homogeneous medium (seawater plus about 1 mM H<sub>2</sub>S), bands slowly advanced as substrates were depleted and the velocity of advance of a band was directly related to the cell density (data not shown); bioconvective patterns appeared for inocula exceeding  $1.7 \times 10^7$  cells ml<sup>-1</sup> (as final cell density in the vessel). In gradients, bands formed at even

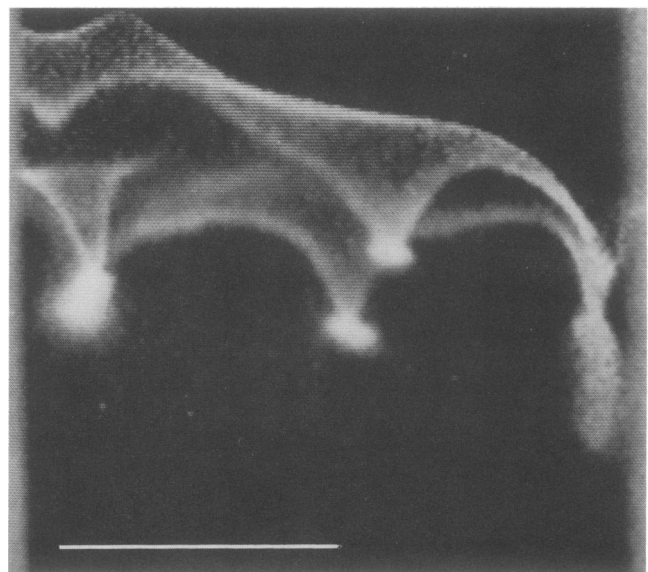

FIG. 1. Photograph of a video recording frame showing bioconvective patterns formed in a band of *T. majus* swarming cells. An inoculum of swarming cells was placed in a glass cuvette containing a sulfide-agar plug at the bottom and filled with oxygenated seawater. White bar, 0.5 cm.

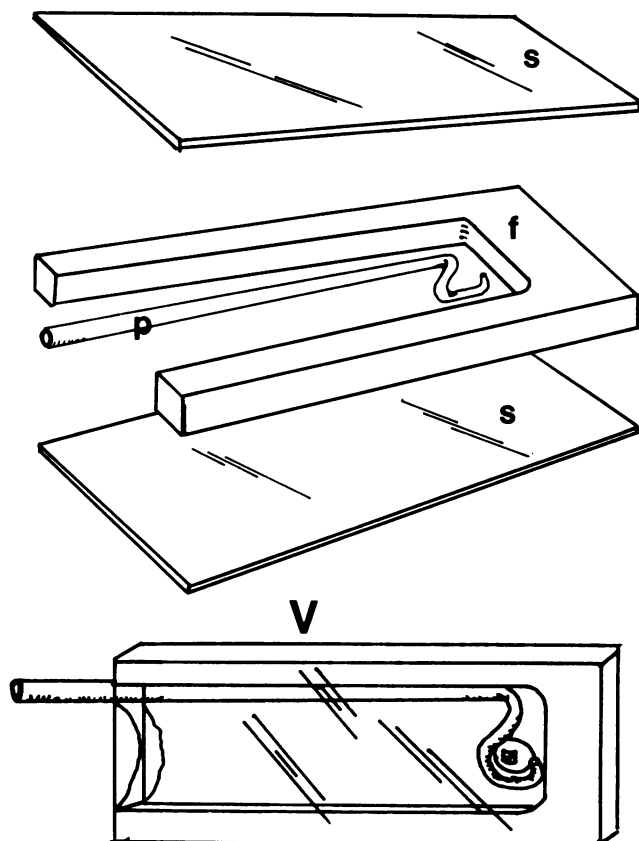

FIG. 2. Construction of microscopic chambers. s, Glass microscope slide; p, bent Pasteur pipette tip; f, plastic frame; V, general view, when assembled and sealed.

smaller cell densities in the inocula, although in such cases the extremely narrow bands formed were almost impossible to locate; bioconvection also appeared with smaller cell densities. Video microscopic recordings revealed that cells swimming towards the band averaged speeds of 612 and 615  $\mu\text{m s}^{-1}$  for two different enrichments (Oregon and Massachusetts, respectively) and showed marked directionality in their trajectories. Cells within the band for the same two enrichments showed speeds of 405 and 306  $\mu\text{m s}^{-1}$ , respectively (Table 1), and displayed a dramatic increase in randomly directed movements (Fig. 3).

For the great majority of bacteria, normal swimming speeds are below 100  $\mu\text{m s}^{-1}$ , with most of them below 50  $\mu\text{m s}^{-1}$ . Speeds measured in *T. majus* represent more than a threefold increase over the bacterial record and fall near the top of the unicellular eucaryotic velocities (Table 2). The cells possess an array of morphologically normal, peritri-

TABLE 1. Measured velocities for *T. majus* swarming cells

Enrichment origin <sup>a</sup>	Situation	<i>n</i> <sup>b</sup>	L ( $\mu\text{m}$ ) <sup>b</sup>	U ( $\mu\text{m s}^{-1}$ ) <sup>b</sup>	<i>s</i> <sup>2b</sup>
Oregon	In band	15	97.2	405	26.5
	Out of band	15	315.2	612	26.0
Massachusetts	In band	12	306.0	306	9.6
	Out of band	10	163.9	615	50.0

<sup>a</sup> See the text.

<sup>b</sup> Abbreviations: *n*, number of cells followed; L, average length of trajectory followed; U, cell velocity; *s*<sup>2</sup>, variance among cell mean speeds.

chous bacterial flagella as motility machinery (2), their sulfide-oxidizing metabolism (12) is shared by many other bacteria which do not swim at such high speeds, and 16S rRNA sequence analyses indicate that *T. majus* is related to *Campylobacter* and *Wolinella* spp. (D. Lane, A. P. Harrison, Jr., D. Stahl, B. Pace, S. Giovannoni, G. J. Olsen, and N. R. Pace, Abstr. Annu. Meet. Am. Soc. Microbiol. 1988, R-15, p. 240), which are not particularly fast swimmers. Although *T. majus* is strikingly large (diameter, 10 to 20  $\mu\text{m}$ ), the size is within the range of low-Reynolds-number swimmers (8). Therefore, major differences in motility machinery, energetic yield of metabolic activity, divergent phylogeny, or physical scenario do not seem to provide a good explanatory basis for high swimming speeds. Nevertheless, the drag force that swarming *T. majus* encounters can be calculated to be 800 times higher than that of an average bacterium (diameter, 1.5  $\mu\text{m}$ ; velocity, 15  $\mu\text{m s}^{-1}$ ) (Table 2). It seems that the bacterial locomotive machinery is displaying its ability to move cells of typical eucaryotic size at typical eucaryotic speeds. High velocities may be necessary to quickly gather enough cells so that their combined action effectively modifies the environment to suit the constraints of such interface-thriving organisms before adverse conditions damage them. A band of cells rapidly responding to small changes in the interface can also be of value during the time when the slime veil is being built up. As Jørgensen and Revsbech (4) observed, *Thiovulum* sp. cells are able to follow the oxygen trail of rapidly swimming phytoflagellates in anoxic environments, and this may represent a means of dispersal of the populations in which high-speed swimming would be indispensable.

The fact that lower speeds are found within the bands can be at least partially explained in terms of fluid dynamics by the retarding effect of the neighbor (increased drag force when a particle moves near neighboring particles or physical boundaries in a fluid, which, in turn, results in a decreased velocity). According to this hypothesis, final cell speeds would depend on the cell density in the bands. The variation

TABLE 2. Compared parameters of microbial swimming

Organisms	U <sup>a</sup> ( $\mu\text{m s}^{-1}$ ) <sup>b</sup>	B/s <sup>a</sup>	Fv <sup>a</sup> ( $10^{-10}$ dyn) <sup>c</sup>	Source or reference
<b>Procarvates</b>				
<i>Pseudomonas aeruginosa</i>	55	37	8	11
<i>Chromatium okenii</i>	45	5	43	11
<i>Thiospirillum jenense</i>	86	2	285	11
<i>Escherichia coli</i>	16	8	3	11
<i>Bacillus licheniformis</i>	21	7	6	11
<i>Sarcina ureae</i>	28	7	11	11
<i>Vibrio comma</i>	200	50	38	9
<i>Thiovulum majus</i>	600	40	1,696	This work
<b>Eucaryotes</b>				
<b>Flagellated</b>				
<i>Ceratium fusus</i>	235	0.56	9,961	1
<i>Euglena viridis</i>	80	1.5	382	1
<i>Monas stigmata</i>	270	45	152	1
<i>Gyrodinium dorsum</i>	328	10	1,066	1
<b>Ciliated</b>				
<i>Tetrahymena</i> sp.	500	7.1	6,579	10
<i>Paramecium</i> sp.	1,000	4.7	39,589	10

<sup>a</sup> Abbreviations: U, characteristic swimming velocity; B/s, cell lengths per second; Fv, viscous drag force experienced by microorganisms.

<sup>b</sup> Velocities in a single organism may vary with conditions. The present values are rounded, characteristic speeds for the organisms.

<sup>c</sup> Calculated from literature data assuming all organisms to be spherical and rigid.

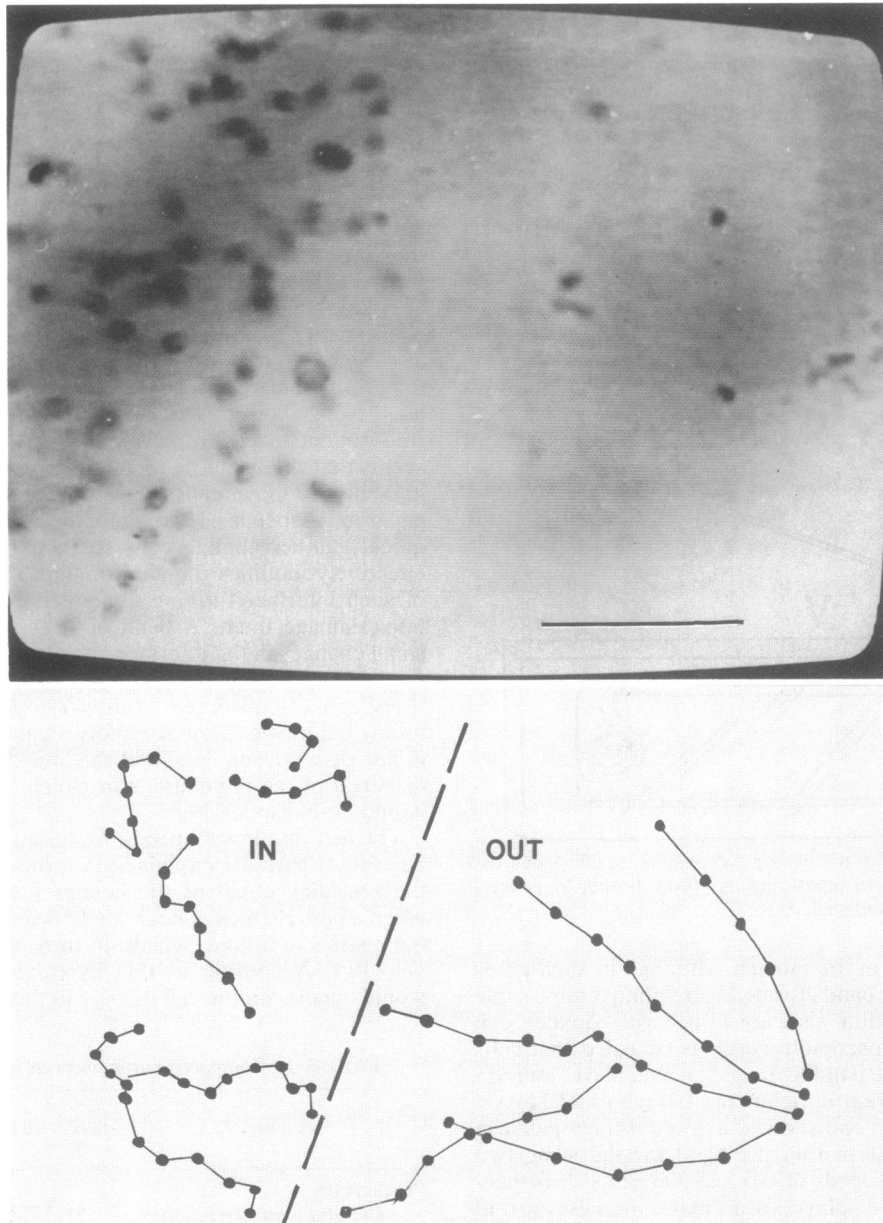

FIG. 3. (Top) Photograph of video microscopy recording frame depicting the edge of a band and several incoming cells. (Bottom) Reconstructed trajectories of swimming cells in and out of the band. Bar, 100  $\mu$ m.

in speeds in the bands (Table 1) may be the result of different cell densities.

This work was partially performed during the 1987 Marine Biological Laboratory (MBL) Microbiology Course in Woods Hole, Mass. I thank the faculty, especially H. W. Jannasch and R. S. Wolfe, and students in the course and at MBL for advice and encouragement.

I was supported by a Fulbright Grant from La Caixa and the United States-Spain Bilateral Commission and am a member of the laboratory of R. W. Castenholz. Thanks are given to him for helpful discussions.

#### LITERATURE CITED

1. Brennen, C., and H. Winet. 1977. Fluid mechanics of propulsion by cilia and flagella. *Annu. Rev. Fluid Mech.* **9**:339-398.
2. de Boer, W. E., J. W. M. la Rivière, and A. L. Houwink. 1961. Observations on the morphology of *Thiovulum majus* Hinze. *Antonie van Leeuwenhoek J. Microbiol. Serol.* **27**:447-456.
3. Hinze, G. 1913. Beiträge zur Kenntnis der farblosen Schwefelbakterien. *Ber. Dtsch. Bot. Ges.* **31**:189-202.
4. Jørgensen, B. B., and N. P. Revsbech. 1983. Colorless sulfur bacteria, *Beggiatoa* spp. and *Thiovulum* spp., in  $O_2$  and  $H_2S$  microgradients. *Appl. Environ. Microbiol.* **45**:1261-1270.
5. La Rivière, J. W. M. 1963. Cultivation and properties of *Thiovulum majus* Hinze, p. 61-72. In C. H. Oppenheimer (ed.), *Symposium of marine microbiology*. Charles C Thomas, Publisher, Springfield, Ill.
6. Levandowsky, M., W. S. Childress, E. A. Spiegel, and S. H. Hutner. 1975. A mathematical model of pattern formation by swimming microorganisms. *J. Protozool.* **22**:296-306.
7. Pfennig, N. 1962. Beobachtungen über das Schwärmen von *Chromatium okenii*. *Arch. Microbiol.* **42**:90-95.
8. Purcell, E. M. 1977. Life at low Reynolds numbers. *Am. J. Phys.* **45**:3-11.

9. **Schlegel, H. G.** 1985. Allgemeine mikrobiologie, 6th ed. Georg Thieme Verlag, Stuttgart.
10. **Sleigh, M. A., and J. R. Blake.** 1977. Methods of ciliary propulsion and their size limitations, p. 243–246. *In* T. J. Pedley (ed.), Scale effects in animal locomotion. Academic Press, Inc., New York.
11. **Vaituzis, Z., and R. N. Doetsch.** 1969. Motility tracks: technique for quantitative study of bacterial movement. *Appl. Microbiol.* **17**:584–588.
12. **Wirsen, C. O., and H. W. Jannasch.** 1978. Physiological and morphological observations on *Thiovulum* sp. *J. Bacteriol.* **136**:765–774.